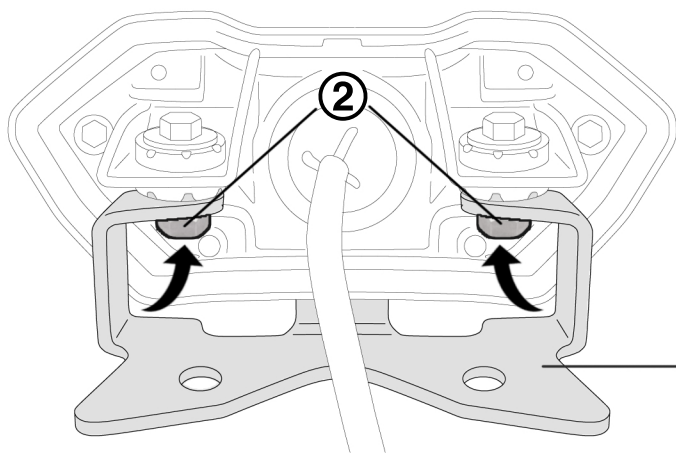
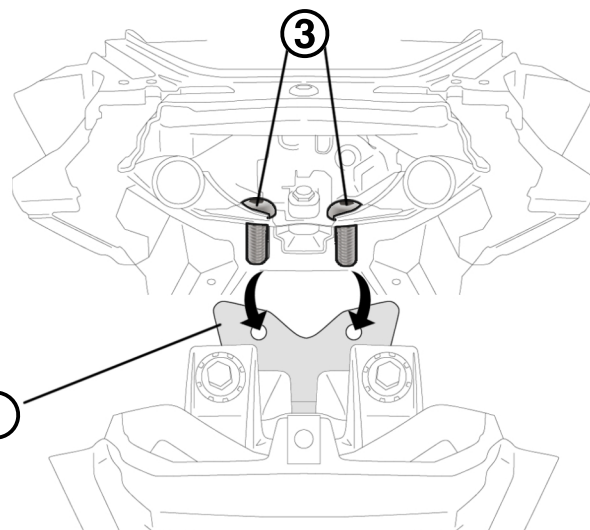
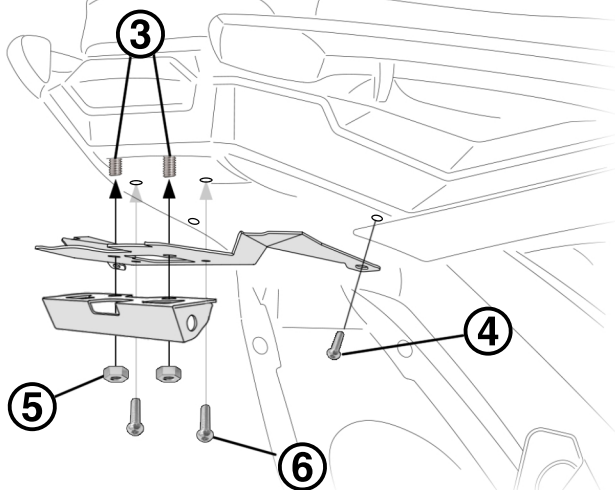
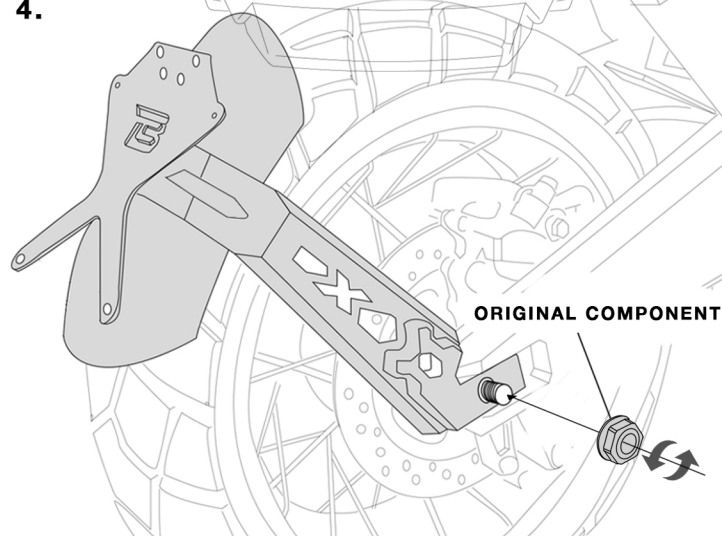

ASSEMBLING INSTRUCTION**LICENCE PLATE****HX7104-17-SN****WWW.BARRACUDAMOTO.COM****LEGEND**

- | | | |
|---|---|---|
| 1. BRACKET
STAFFA
SOPORTE
UNTERSTÜTZUNG
SUPPORT | 3. SCREW M8X16
VITE M8X16
TORNILLO M8X16
SCHRAUBE M8X16
VIS M8X16 | 5. NUT Ø8
DADO Ø8
TUERCA Ø8
MUTTER Ø8
ÉCROU Ø8 |
| 2. NUT Ø6
DADO Ø6
TUERCA Ø6
MUTTER Ø6
ÉCROU Ø6 | 4. SCREW M5X16
VITE M5X16
TORNILLO M5X16
SCHRAUBE M5X16
VIS M5X16 | 6. SCREW M6X14
VITE M6X14
TORNILLO M6X14
SCHRAUBE M6X14
VIS M6X14 |

1.**2.****3.****4.**

EN: TIGHTEN THE ORIGINAL NUT WITH A DYNAMOMETRIC KEY AS PER HONDA SPECIFICATIONS

IT: SERRARE IL DADO ORIGINALE CON CHIAVE DINANOMETRICA COME DA DA SPECIFICHE HONDA.

ES: APRIETE LA TUERCA ORIGINAL CON UNA CLAVE DINANOMETRICA SEGÚN LAS ESPECIFICACIONES DE HONDA.

DE: ZIEHEN SIE DIE ORIGINALMUTTER MIT EINEM DYNAMOMETRISCHEN SCHLÜSSEL NACH HONDA-SPEZIFIKATIONEN AN.

FR: SERREZ L'ÉCROU ORIGINAL AVEC UNE CLÉ DYNAMOMÉTRIQUE SELON LES SPÉCIFICATIONS HONDA.